



USER MANUAL

SOAPTAP Model 378, 478, 738

FOAMTAP Model: 382, 482, 742

TABLE OF CONTENTS

Dimensions and technical specifications 3
 General safety information 4
 Installation 5
 Installation height 8
 Product application 8
 Light indicator 8
 Cleaning and maintenance 9
 Refill of soap reservoir 9
 Timer settings 10
 Troubleshooting and corrective actions 11
 Parts list 12

3
4
5
8
8
8
9
9
10
11
12

DIMENSIONS AND TECHNICAL SPECIFICATIONS

Dimensions

Unit of measurement: mm

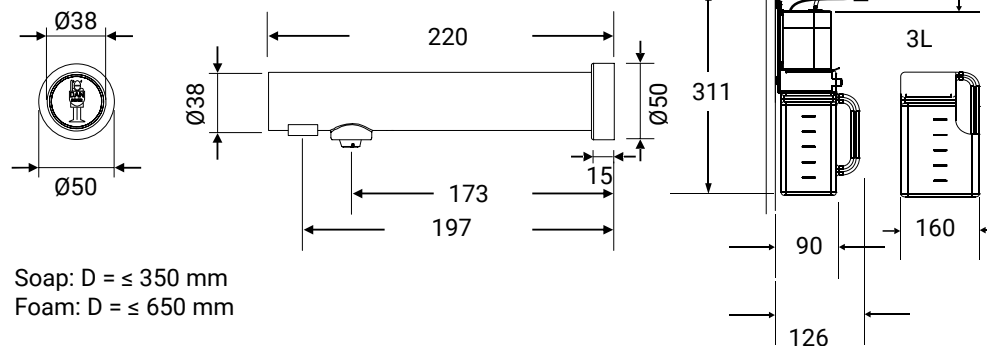

Soap: D = ≤ 350 mm

Foam: D = ≤ 650 mm

TECHNICAL SPECIFICATIONS

DESCRIPTION	DATA
Material	Stainless steel - AISI 304
Voltage	6V DC, AC/DC adapter is included
Stand-by power	0.3-0.4W
Sensor type	Infrared, self adjusting
Sensor range	20 mm - 150 mm. Standard 120 mm ± 20 mm, adjustable.
Soap/foam dosing volume	1-1.5 ml (soap), 0.6-0.8 ml (foam)
Soap pump service life	100,000 activations
Mechanism service life	500,000 activations
Soap container	1,500 ml, optional 3000 ml
IP Class	IP35
Net weight	1.9 kg
Gross weight	2.3 kg

IMPORTANT!

This product falls within the scope of the WEEE directive on recycling and recovery of waste electrical and electronic equipment.



- This product should not be disposed of with general household waste.
- This product must be reused if possible.
- Contact your local authority for further details.
- This product may also be returned to the manufacturer/retailer for proper treatment, recovery and recycling.



PRODUCT TYPE / MODEL

378 Stainless steel, satin finish, SoapTap Wall

382 Stainless steel, satin finish, FoamTap Wall

478 Stainless steel, black PVD coating, SoapTap Wall

482 Stainless steel, black PVD coating, FoamTap Wall

738 Stainless steel, PVD coating, SoapTap Wall

742 Stainless steel, PVD coating, FoamTap Wall

GENERAL SAFETY INFORMATION

WARNING

- Turn off the power to the unit before servicing or cleaning.
- Never modify the product.
- Never insert objects into any opening in the product.
- The product is not intended for playing purposes.
- Cleaning and user maintenance must be carried out by children.
- The product may only be used for the applications described in this manual.
- Do not use any accessories not recommended by the manufacturer.
- The product should be checked on a regular basis. Never use a defective or malfunctioning unit
- Never make alterations to the product affecting its performance. DAN DRYER's product warranty does not cover product problems that result from misuse or alteration.

NOTE

If the power supply cord is damaged, it must be replaced immediately. Disconnect the electricity supply cord according to instructions.

This product is not intended for use by persons (inclusive children) with reduced physical, sensory or mental capabilities, or lack of experience and knowledge, unless they are supervised or have been given instruction concerning use of the product by a person responsible for their safety.

Children should be supervised to ensure this product is used correctly.

INSTALLATION

- Make sure the main breaker is turned off. Installation must be carried out by a qualified person in accordance with applicable standards in the country concerned.

1a. Check the required distance from sensor to sink.

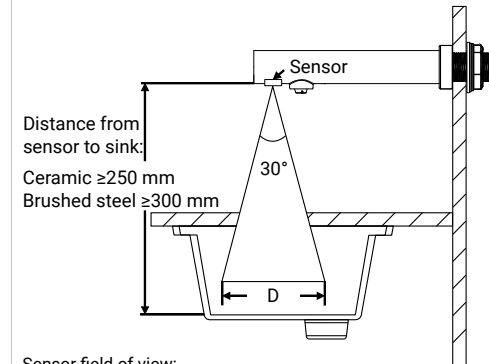

Objects within range D may cause unintentional activation.

1b. Check the required distance from sensor to sink.

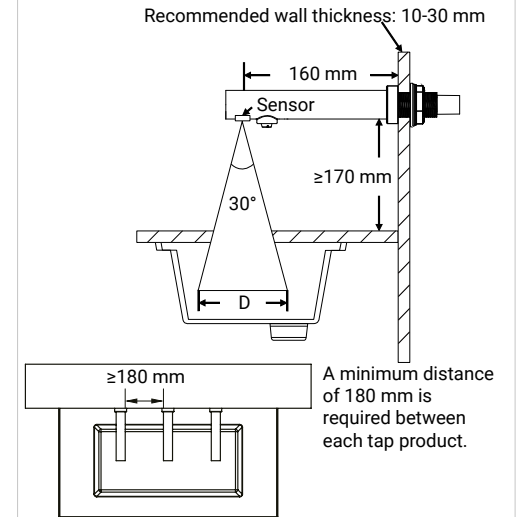

2. Mark the desired position on the wall and drill a $\varnothing 35$ mm diameter hole.

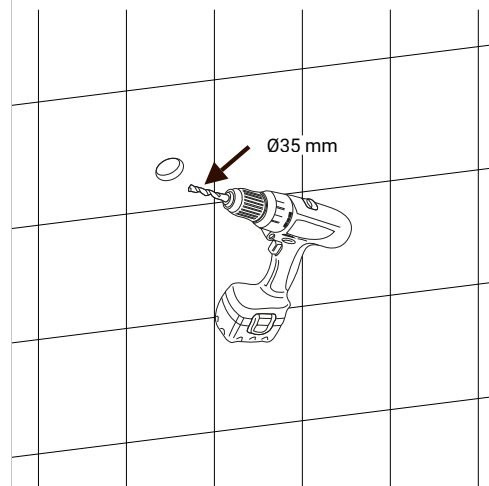

3. Installation of the tap:

- Push the screwed bushing through the hole in the wall
- Place gasket, disc, and nut on the threaded coupling of the tap
- Tighten with tool, be careful not to overtighten the nut

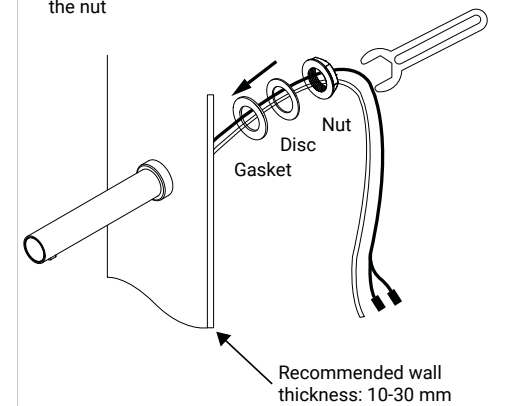

INSTALLATION

4. Use a template to drill the holes for the bracket. Install bracket close to Soap/Foam Tap; behind a wall, in a cabinet, or under the sink.

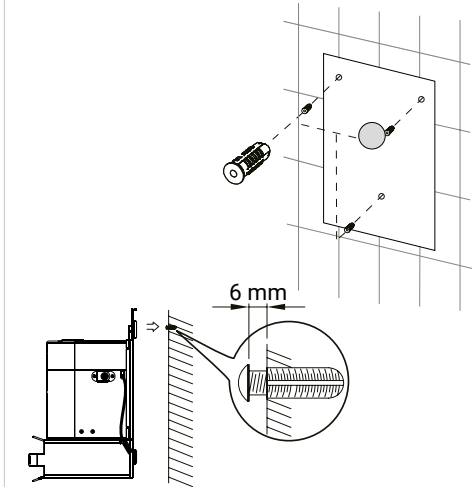

5. Fasten bracket into the pre-drilled holes.

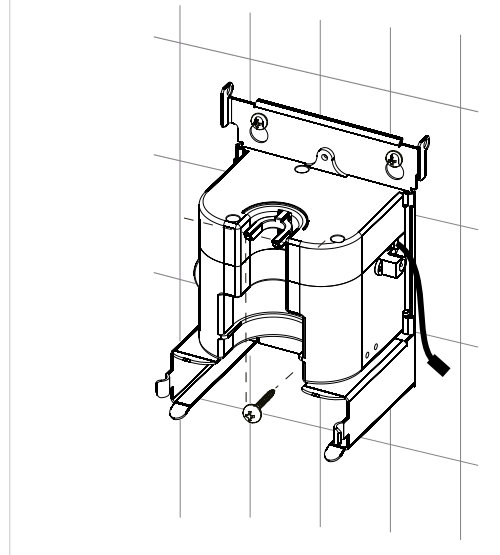

6. Connect the soft rubber tube to the outlet of the pump, and place the pump into the soap container.

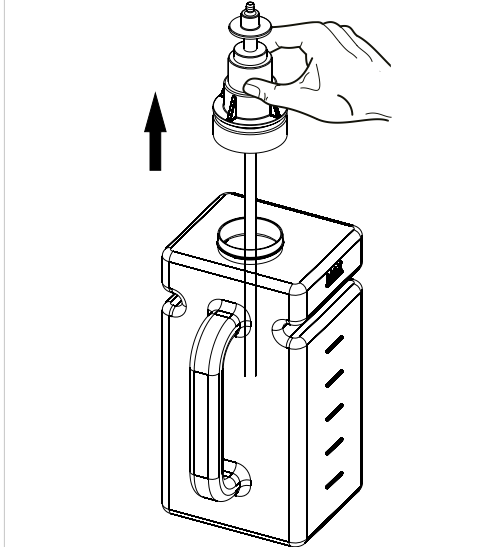

7. Connect the tube to the pump and the cables to the control box.

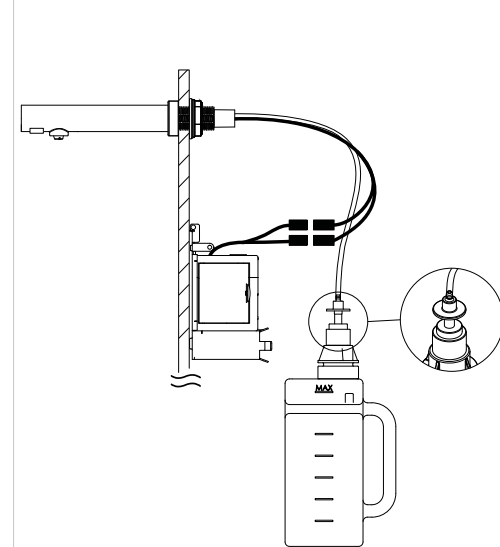

INSTALLATION

8. Insert soap container 1.5 or 3 L. Confirm the container is placed correctly to activate the dispenser. The fork should be on top of the disc at the pump top.

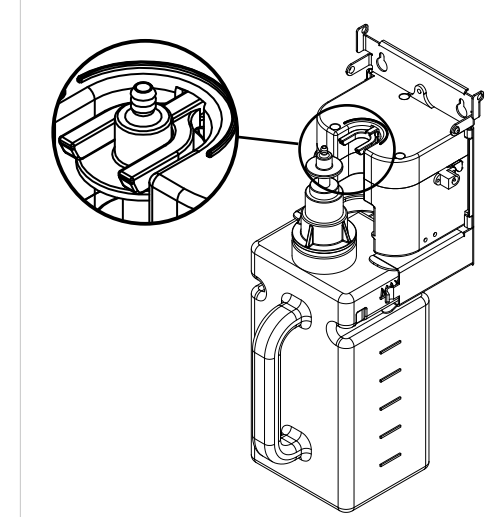

9. Connect 6 V DC power supply to control box.

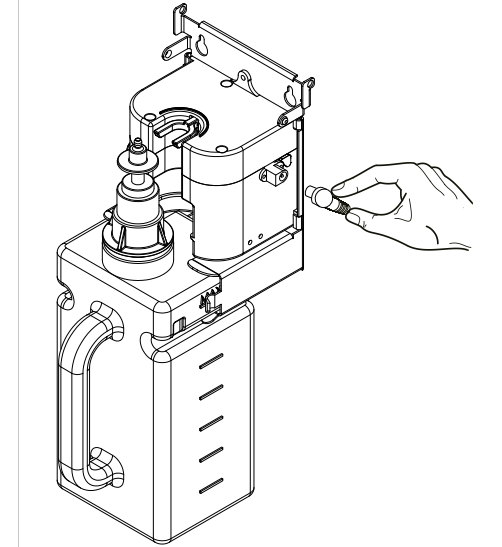

INSTALLATION HEIGHT

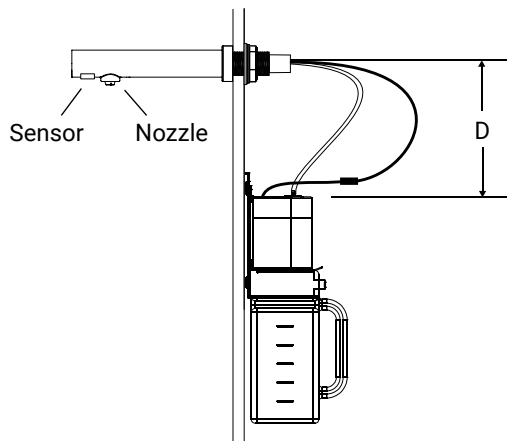

Soap: $D = \leq 350\text{mm}$
 Foam: $D = \leq 650\text{mm}$

IMPORTANT!

- Ensure easy access to maintenance and cleaning of the unit.
- It is recommended to install a power switch to the soap dispenser to ensure easy disconnection of the electricity supply before cleaning and maintenance.
- Do not bend the hose too sharp. It can increase the resistance in the hose and reduce the ability of the pump to deliver a full dose.
- Ensure unit is installed on solid and stable background.
- Pay attention to the different properties of the different liquids, depending on the type of pump.

PRODUCT APPLICATION

- Place your hands approx. 10-14 cm under the sensor to activate the dispenser. The dispenser will deliver 1-1.5 ml soap (0.6-0.8 ml foam)
- Remove hands after soap release
- Stops automatically when hands are moved away

LIGHT INDICATOR

Standby	Solid green light
Active	Pulsing light from green to red
Wrong type of soap/obstruction	Flashing green and red light
Empty soap reservoir*	Flashing green light

* Light indication for empty soap reservoir is based on a counter that resets when power is switched off, e.g. when refilling soap. The calculation is based on a 1.5 L soap reservoir and will call for soap refill every 1.2 L (approx. 1000 activations). If using foaming soap the empty reservoir indication flashes even though the reservoir is still half full. Remove reservoir from wall bracket and place it back to reset the SoapTap unit.

CLEANING AND MAINTENANCE

Routine cleaning and maintenance is recommended.

REFILL OF SOAP RESERVOIR

- Remove soap reservoir and pump unit from the control box
- Remove pump from soap reservoir and fill with soap
- Put the pump back in the filled reservoir. Install soap reservoir and pump in the control box
- NB! **Do not** remove the soft hose from the pump

CLEANING AND MAINTENANCE OF CONTROL BOX

- Cut the power
- Remove any dust and dirt
- Do not rinse with running water
- Use a damp cloth and mild cleaning solution. Never use cleaning detergents with an abrasive effect

CLEANING AND MAINTENANCE OF TAP/SENSOR

- Do not rinse with running water
- Use a damp cloth and mild cleaning solution. Never use cleaning detergents with an abrasive effect
- Clean sensor for dust and dirt to prevent unintentional activation

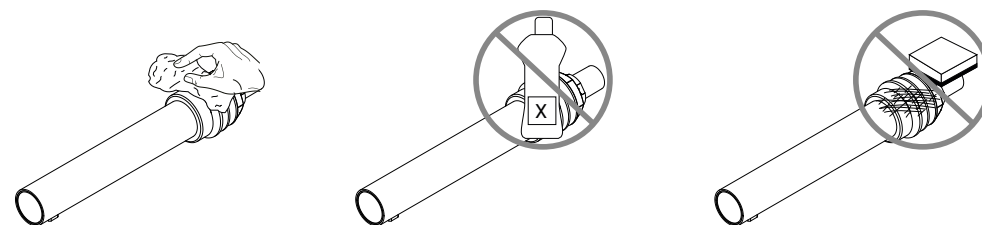



TIMER SETTINGS

CALIBRATION OF SENSOR RANGE

- Cut the power
- Connect power to the dispenser
- Place your flat hand close to the sensor until the green light on the front of the tap turns off and starts flashing red.
- Move your hand to the desired activation distance
- The calibration setup has completed with the new distance when it starts blinking green again.

TROUBLESHOOTING AND CORRECTIVE ACTIONS

SYMPTOM	CORRECTIVE ACTION
The dispenser has stopped dispensing	<ul style="list-style-type: none"> • Ensure power is on. • Ensure the soap reservoir is installed properly in its holder. • Ensure the hose is not bent or twisted. • Ensure the tubing is installed correctly and fits tightly. A broken hose will not fit tightly on the pump, soap will be dripping and it will eventually damage the control box. • Ensure exit nozzle, hose and pump are not clogged. • Ensure that soap meets specified viscosity range: SOAPTAP 378/478 viscosity 1cP - 3000cP. FOAMTAP 382/482 viscosity 1cP.
Soap dispenser is malfunctioning	<ul style="list-style-type: none"> • Check the IR-sensor works properly (see section for light indication p. 8). • Clean sensor for dirt. • Cut off power and reconnect to restart the system. • You could try to calibrate the sensor range (see section for sensor calibration). • If the problem persists, replace the sensor.
The soap dispenser sounds strained and it does not dispense a full dose	<ul style="list-style-type: none"> • Ensure there are no bends, knots or kinks on the hose. • Check if the nozzle, hose or pump is clogged. • Ensure that soap meets specified viscosity range: SOAPTAP 378/478 viscosity: 1cP - 3000cP FOAMTAP 382/482 viscosity: 1cP
Flashing green light	<ul style="list-style-type: none"> • Confirm the unit's reservoir is filled with soap. • If soap reservoir is not empty, remove reservoir from wall bracket and place it back to reset light indicator for empty soap reservoir.

PARTS LIST

No.	Description
1	TAP wall-mounted
2	End piece
3	LED circuit board
4	Holder for LED circuit board
5	Sensor and nozzle silicone liner
6	Sensor and holder for nozzle (lower part)
8	Holder for nozzle (upper part)
9	Bushing Ø34 mm with thread
10	Rubber gasket for bushing
11	Disc
12	Gasket big
13	Nut
14	Tube/nozzle connecting link
15	Nozzle for FOAM
16	Nozzle for SOAP
18	Soap tube for SOAP/FOAM
19	Control box
20	Mounting plated for control box and soap container
21	Tools for fastening of nut
22	Soap container 1.5 L / 3 L
23	Pump FOAM
24	Pump SOAP
25	AC-adapter

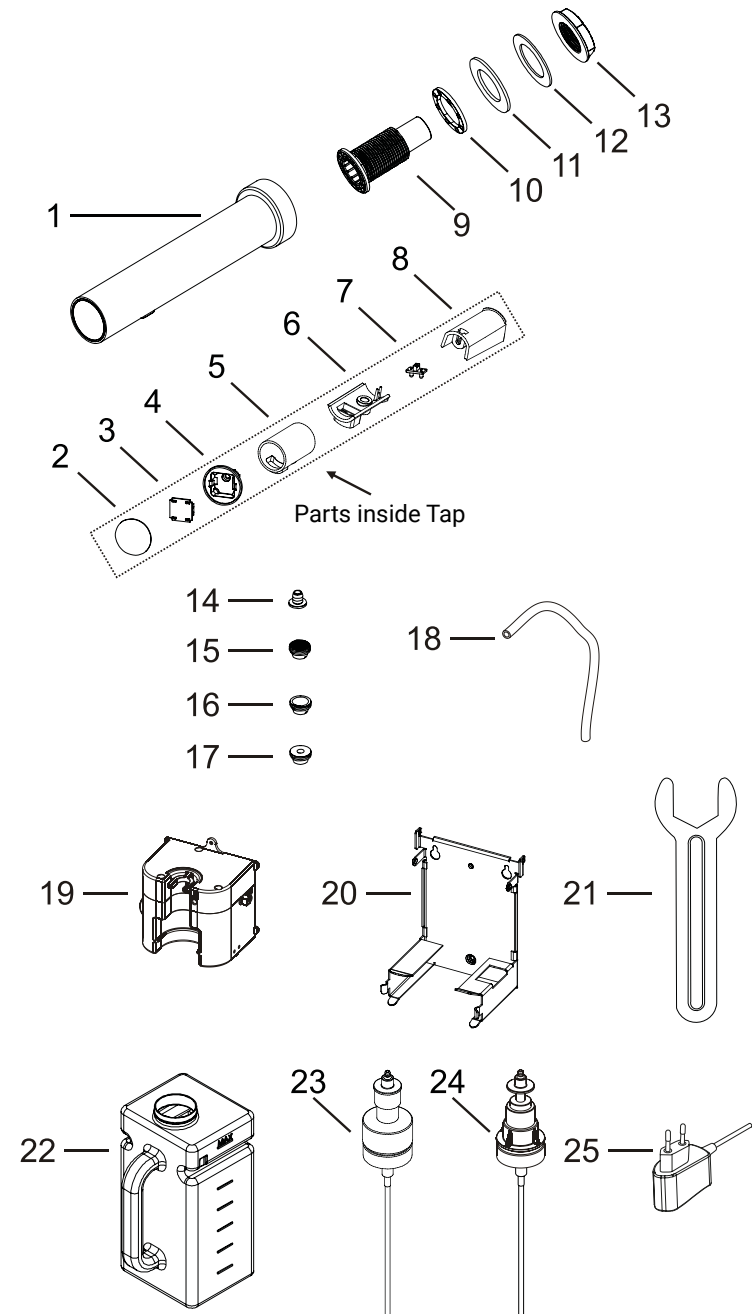



DAN DRYER A/S

Tåsingevej 2
DK - 8940 Randers SV

+45 8641 5711
info@dandryer.com
dandryer.com

